

BenQ Projectors

Displays



BenQ projectors can be controlled with Mira Connect™, Aveo Systems’ smart control appliance. Mira Connect communicates and controls BenQ projectors over a network or RS-232 connection.

! If controlling the BenQ projector over LAN, ensure Network Settings > Network Standby is set to **On** to keep the network interface alive when the projector is powered off.

Follow these steps to integrate a BenQ projector with Mira Connect:

Step 1

Add the BenQ projector to the room

Add the BenQ projector to the room in Mira Portal (<https://mira.aveosystems.com>), and enter the IP address of the projector, or if controlling over RS-232, enter the IP address of the Global Cache IP2SL interface.

If you don’t have a BenQ projector yet, you can enable ‘Simulate equipment’ and continue setting up the system and building the user interface.

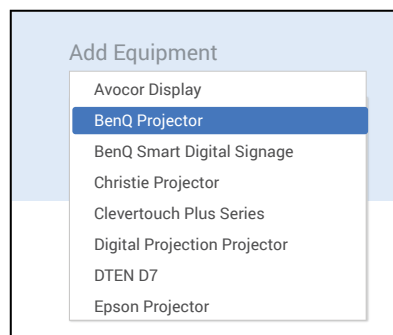

Step 2

Enable Video Inputs on the BenQ projector

Navigate to the Video Inputs tab and specify which video inputs are used on the device. Not all inputs listed may be available on the selected model.

Enable an input, select an icon, and enter text labels for the desired inputs. This will create a display menu as shown in the following figure.

If using sources from tuners or video switchers, click the ‘Use Sources Connected to Other Equipment...’ link and select the device where the video input is coming from.

The display menu will be built and previewed on the VIDEO INPUTS tab within Mira Portal. An optional display name may be entered which is useful if you have multiple displays or projectors in a room.

You can re-arrange the order of the items in the display menu by clicking and dragging an input in the Menu Preview.

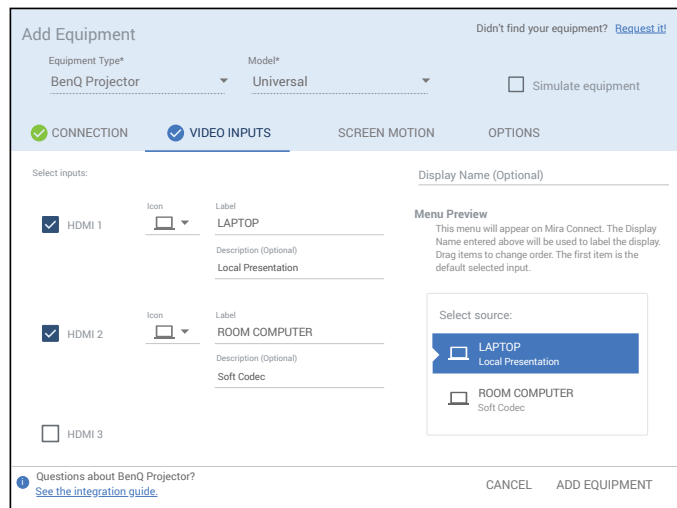
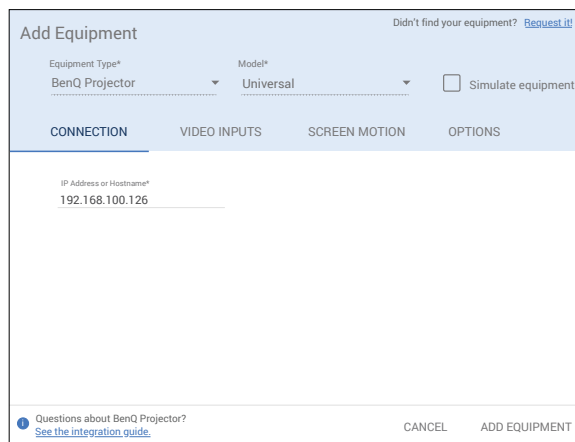

Click **Add Equipment** when done to connect to the BenQ projector.



Step 3

Connect to the BenQ projector

Once the equipment is added, Mira Connect will connect to the BenQ projector and show the status of the connection.

Mira Portal will show the equipment status as a green circle, , if the IP address is valid and Mira Connect can communicate to the device, otherwise the warning symbol, , will appear indicating the IP address is not correct or Mira Connect does not have a network route to the device.

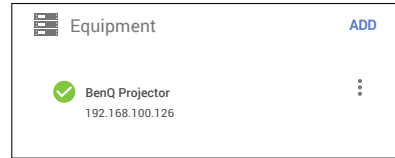
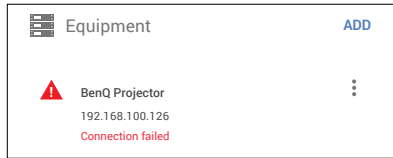

See the [Mira Connect Administrators Guide](#) for more information about using Mira Portal to set up Mira Connect.

Important information about the integration is summarized below.

Control Interface

Network connection using TCP, port 8000 for direct network control.

Network connection using TCP, port 4999 when using the Global Cache IP2SL for RS-232 control.

If using the Global Cache IP2SL interface for serial control, see our Global Cache [integration guide](#). Ensure the baud rate on the Global Cache IP2SL matches the baud rate configured on the display. Since the default RS-232 settings for BenQ projectors is 9,600 baud, no parity, 8 data bits, one stop bit, and no flow control, you will need to change the baud rate on the Global Cache device. Typically the cable is a cross-over DB9F to DB9F.

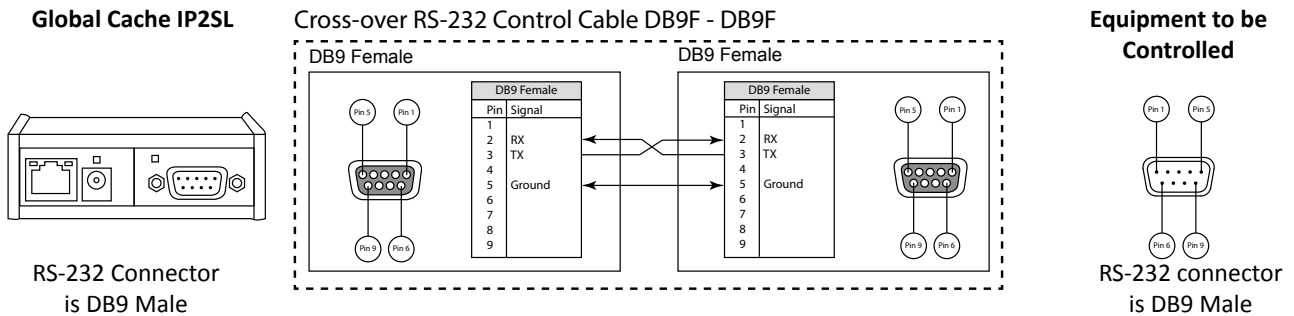

Set a static IP address, or use a 'reserved' lease on a DHCP server to ensure the IP address does not change over time. See the Global Cache [integration guide](#) for how to change the baud rate and how to set a static IP address.

Supported Control

Supports power on/off, video source selection, display freeze, display blank, volume, and audio mute control.

Supported Models

Mira Connect supports the LK952 and other BenQ projectors that use that same control protocol. If you have a different model that you need supported, please contact us: <https://aveosystems.com/equipment/#request>

Software Versions

Tested against the BenQ LK952.

Troubleshooting

If the projector shows a Connection failed message or isn't responding to commands, check:

- The RS-232 baud rate of the Global Cache IP2SL interface. Change the default value of the Global Cache from 19,200 to 9,600.
- The IP address of the display matches the IP address entered in Mira Portal and that Mira Connect is on the same network or has a network route to the display.
- If the projector won't power on after having been powered off, double check the projector's low power setting to ensure "On by LAN" is enabled.

For more information please contact our Sales Department at sales@aveosystems.com.

About Aveo Systems

Aveo Systems is a leading provider of intuitive and easy-to-use solutions for audio, video, and collaboration, improving how systems are used and managed by customers worldwide.

Specifications subject to change without notice. Aveo Systems and the Aveo logo are registered trademarks. All other trademarks are the property of their respective owners.



DS-11128-001
Version 20230319